

# Tube Feeding by Gravity

## Information for patients and families

Read this book to learn:

- How to use your feeding tube
- How to keep it clean
- Common problems
- What you can do about them



# Table of contents

Section A: Your tube feeding schedule.....page 3  
Section B: Parts of your feeding tube.....page 4  
Section C: Before you use your feeding tube .....page 5  
Section D: How to use your feeding tube .....page 9  
Section E: After using your feeding container tubing .....page 20  
Section F: Common problems and what to do.....page 22

**Patient's Name:** \_\_\_\_\_

**Date:** \_\_\_\_\_

**Registered Dietitian:** \_\_\_\_\_

**Phone:** \_\_\_\_\_

## Section A: Your tube feeding schedule

Name of formula: \_\_\_\_\_

Amount of formula: \_\_\_\_\_

Feeding rate: \_\_\_\_\_

Schedule: \_\_\_\_\_  
\_\_\_\_\_  
\_\_\_\_\_  
\_\_\_\_\_

Amount of water to flush: \_\_\_\_\_  
(before and after feeding)

Additional water flushes: \_\_\_\_\_  
\_\_\_\_\_  
\_\_\_\_\_  
\_\_\_\_\_

**This will give you \_\_\_\_\_ calories and \_\_\_\_\_ mL of water each day.**

## Section B: Parts of your feeding tube

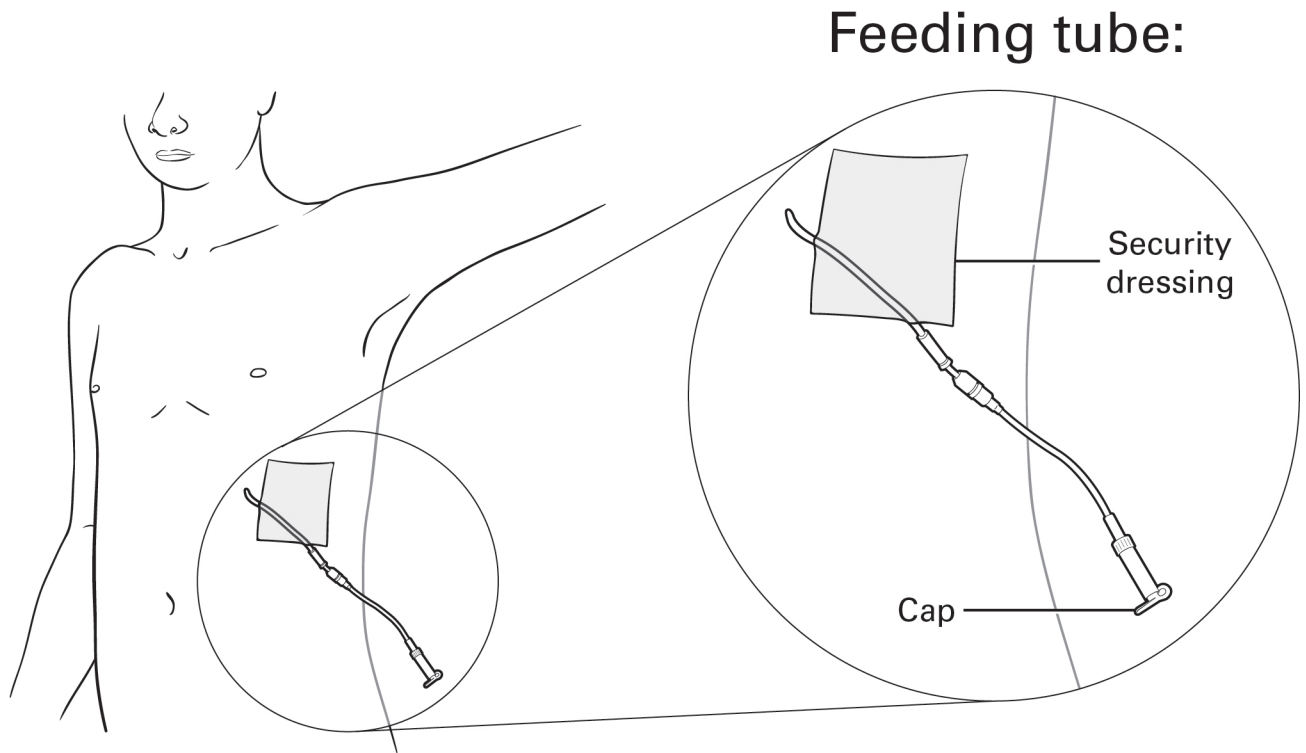

## Section C: Before you use your feeding tube

### Read this section to learn:

- ✓ What to collect before you use your feeding tube
- ✓ How you need to prepare

### Follow these steps before you use your feeding tube:

#### Step 1: Clean your work surface.

This will help reduce contact with harmful bacteria (germs).

#### Step 2: Collect these things.

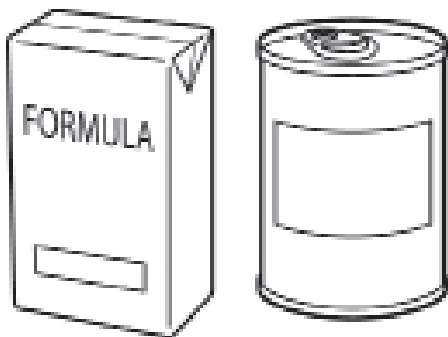

#### Formula

Formula is liquid food. It usually comes in a can or a Tetra Pak® box. The formula has all the nutrients, vitamins and minerals you need to stay healthy.

Store the formula at room temperature when unopened. Keep it away from direct sunlight or heat. If you have leftover formula, store it in the fridge. Let it come to room temperature before you use it.

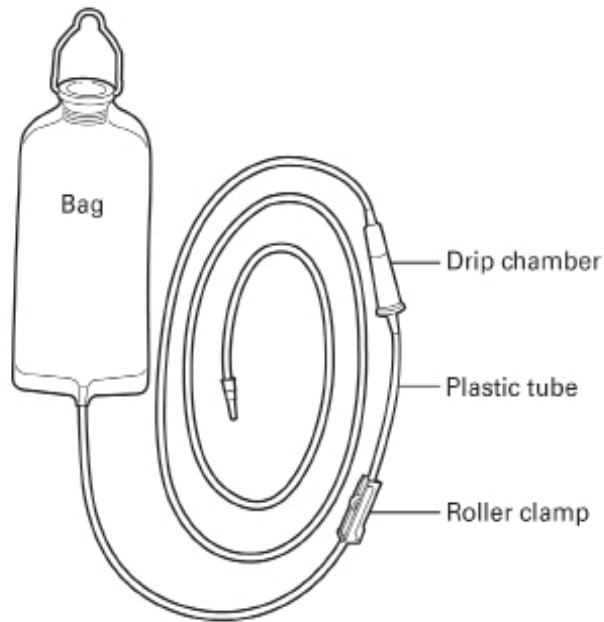

## Feeding container with tubing

The feeding container is the plastic container or bag. The container holds the formula. The formula flows from the container through the tubing into your feeding tube.

### A complete set contains:

- **Container** to hold the formula.
- **Drip chamber** that connects the container to the tubing. The drip chamber lets you see how fast the formula is flowing through the tubing.
- **Roller clamp** to control the rate the formula flows into the tubing.
- **Plastic tube** with a tip that connects the feeding container tubing to the feeding tube in your body.

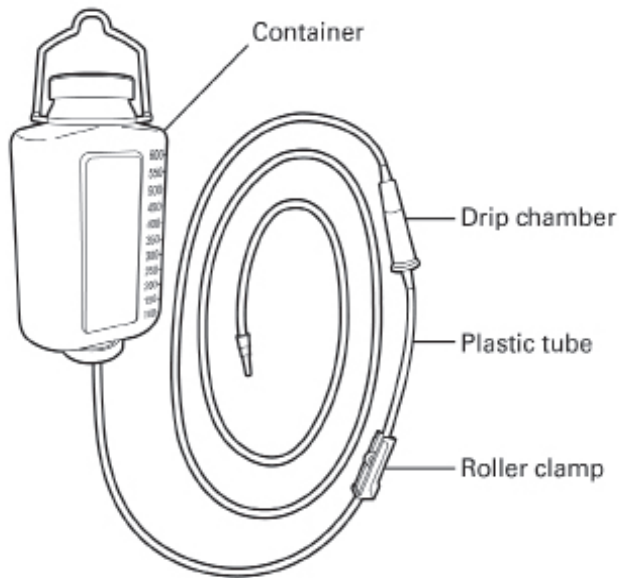



### **Catheter-tip syringe (60 ml, equal to 2 ounces)**

This is a plastic syringe that has a 3 cm (1 inch) tip on it. You will use this to flush your feeding tube with water and to give medicine.

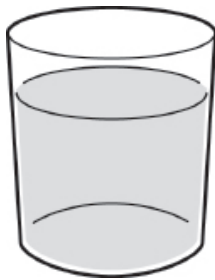

### **Glass of room temperature water**

Use room temperature water to flush your feeding tube. Flush your feeding tube to make sure it does not get blocked. **Do not use cold water.** Cold water can give you stomach pain or cramps.



### **Clean paper towels**

Use paper towels to protect your clothes from spills.



### **Something to hang your feeding container from**

You can hang your container from many things.

Try using:

- An IV stand
- A coat rack
- A hook in the wall or ceiling
- A clothes hanger over a door

### Step 3: Wash your hands.

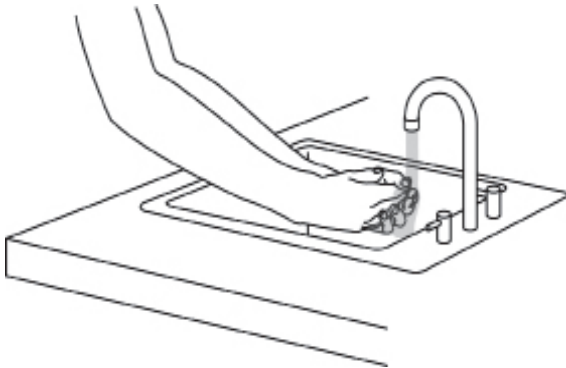

**Wash your hands with soap and water.**

Dry your hands using a clean towel.

### Step 4: Get comfortable.

Make sure you are comfortable and entertained while receiving your feeding. It will help make the time more pleasant. It can take a long time to finish your feeding. Be prepared and plan ahead.

Use these tips to make your feeding more comfortable:

- Choose a room that is bright and cheerful to have your feeding.
- Entertain yourself with books or crossword puzzles.
- Watch your favourite programs or movies on TV.
- Listen to relaxing music.
- Invite a friend or family member to keep you company.
- Sit in a comfortable chair. You can also sit up in bed. Use pillows to prop yourself up. Your upper body should be raised at least 30 to 45 degrees.



## Section D: How to use your feeding tube

### Read this section to learn:

- ✓ How to flush your feeding tube
- ✓ How to feed yourself through your tube

Follow the 7 steps below to use your feeding tube:

### Step 1: Put the formula in the feeding container.

**Do not put blended or pureed food or other liquids into the feeding container.** Only use store-bought formula approved by your dietitian.

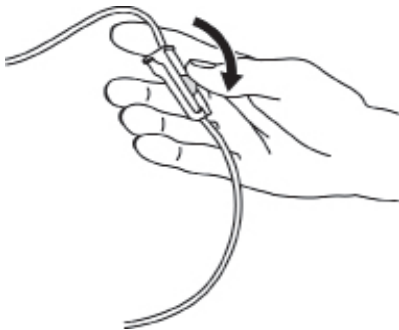

- A. Close the roller clamp on your feeding container. This will stop the formula from flowing into the tube.



- B. Shake the formula. Wipe the cover with a clean cloth. Open the formula.



C. Use 1 hand to hold the container and the end of the tube. Hold them in a vertical upright position so that the tube makes a "U" shape.

D. Open the lid of the feeding container. Pour the formula into the container.

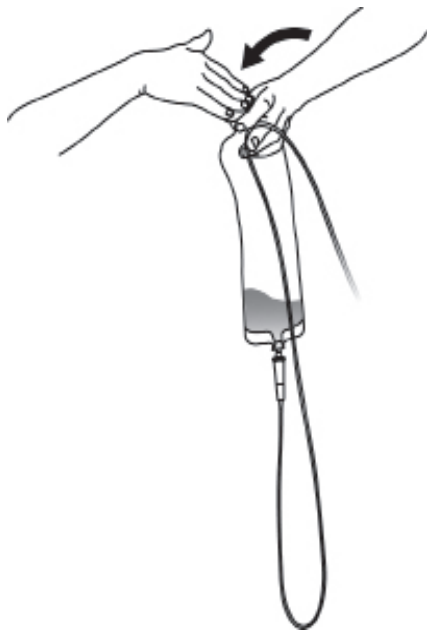

E. Close the lid on the feeding container.

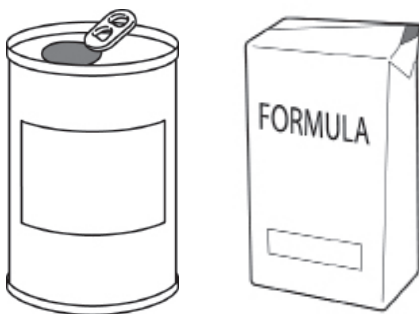

F. Keep the empty can or Tetra Pak<sup>®</sup> because you will use it later.

## Step 2: Hang the feeding container.

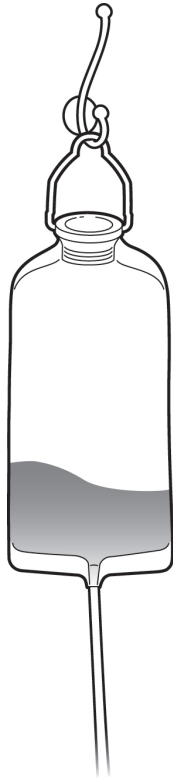

Hang the container. Hang it above your shoulder when you are seated.

## Step 3: Let the formula flow through the tubing.

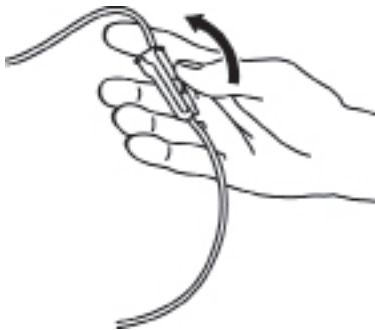

A. Slowly open the roller clamp. The formula should start to flow down the tube.

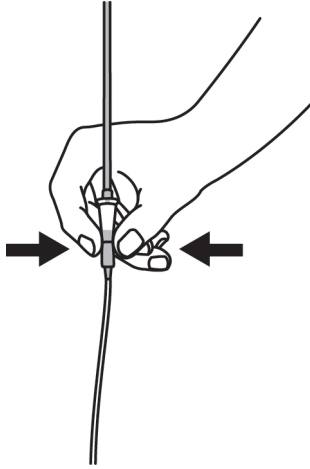

If the formula is not flowing, try:

- Squeezing the bag lightly.
- Opening up the lid on the feeding container to allow some air in.
- Squeezing the drip chamber.

B. Turn the drip chamber upside down. Let the formula fill it half full. Then turn the drip chamber upright again.

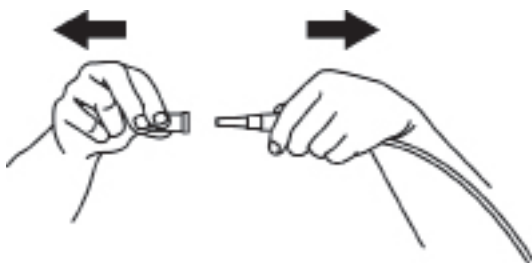
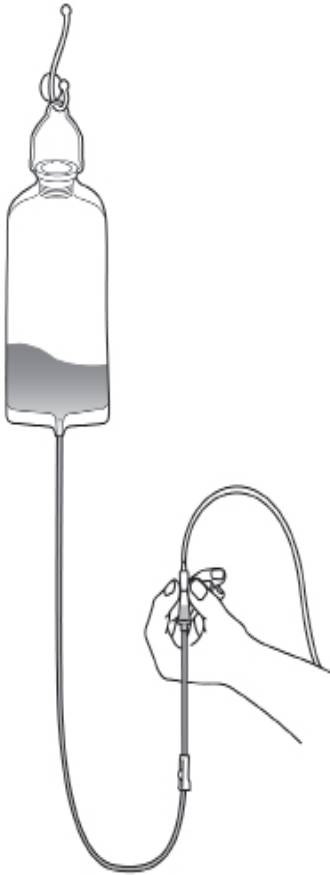

C. Remove the cap of the feeding container tubing. Place the end into the empty formula can or Tetra Pak® that you saved.

D. Let the formula run through the tubing to push out any extra air.



E. Close the roller clamp when the formula gets to the end of the tubing.

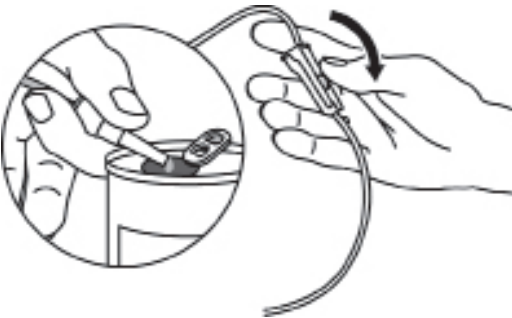

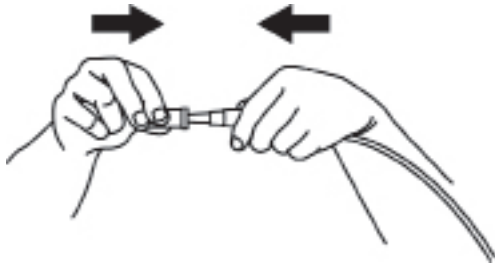

F. Put the cap back on the end of the tubing.

#### Step 4: Flush your feeding tube.

Flush the feeding tube in your body with water once your feeding container is ready. Flushing your tube will make sure it is working well and is not blocked.

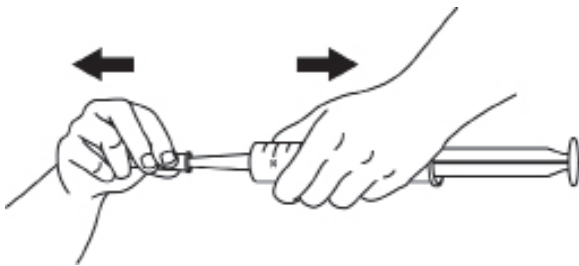

A. Remove the cap from your syringe.

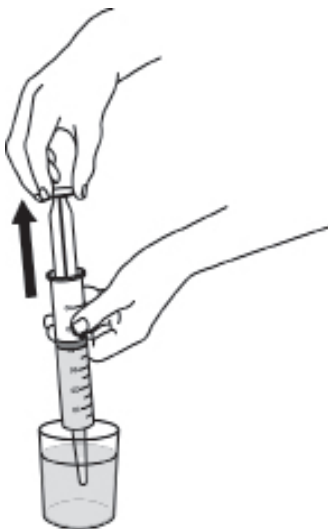

B. Place the tip of the syringe below the waterline. This will help make sure no air goes into the syringe. Fill the syringe with \_\_\_\_\_ millilitres of room temperature water.



- C. Aim the tip of the syringe up in the air. Squeeze a tiny bit of water out of the tip. Make sure there is no air left in the syringe.

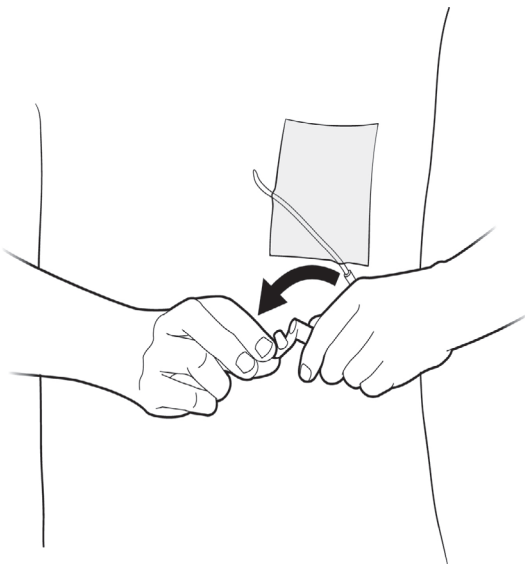

- D. Remove the cap from your feeding tube.

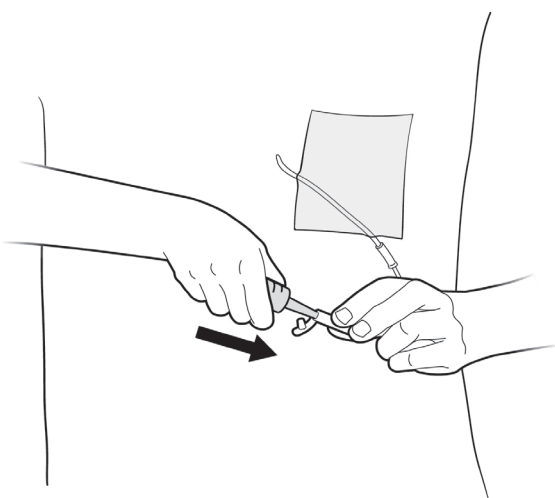

- E. Insert the tip of the syringe into the end of your feeding tube.

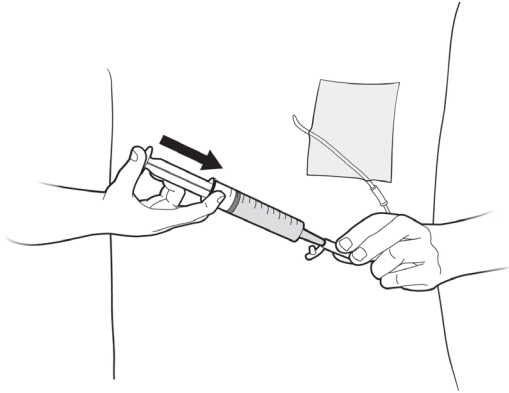

F. Slowly push the plunger on the syringe. The water from the syringe will go into your feeding tube.

G. Remove the syringe and place the caps back on the feeding tube and the syringe.

### Step 5: Connect the feeding container tubing to your feeding tube.

After you flush your feeding tube, you are ready to connect the feeding container tubing to the feeding tube in your body.

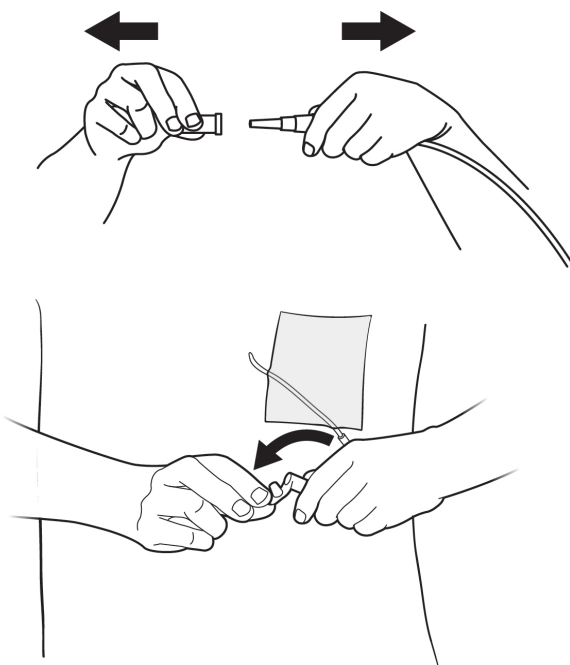

A. Remove the cap from the feeding container tubing and the cap from your feeding tube.



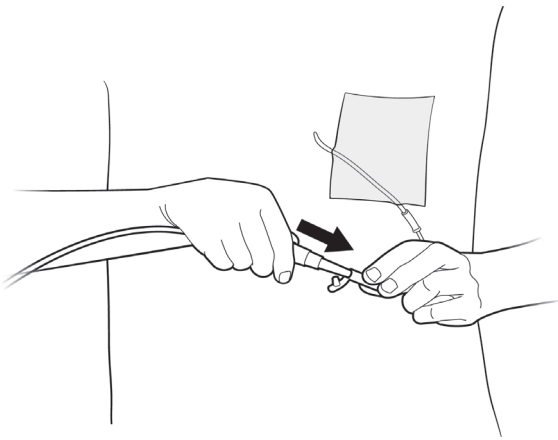

B. Put the tip of the feeding container tubing into your feeding tube.

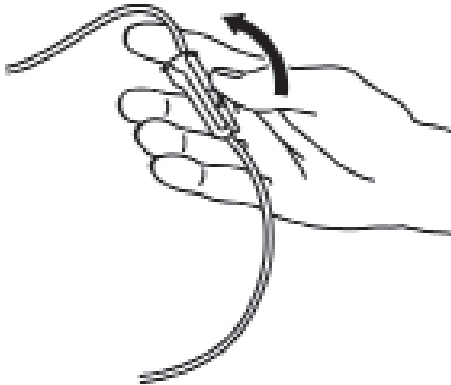

C. Open the roller clamp on the feeding container tubing. Let the feeding formula drip at a steady rate.

Check the flow of the formula from time to time. You can expect it to take about an hour for each box of feed.

You can adjust the speed to go slower or faster. It depends on your comfort and how your body reacts to the feeds.

Moving the roller clamp:

- up (↑) will make the formula drip **faster**
- down (↓) will make the formula drip **slower**

## Step 6: Finish your feeding.

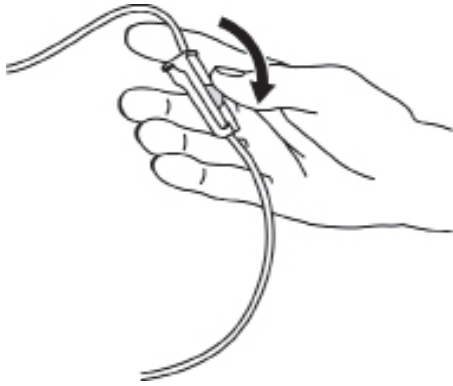

- A. Close the roller clamp on the feeding container tubing.

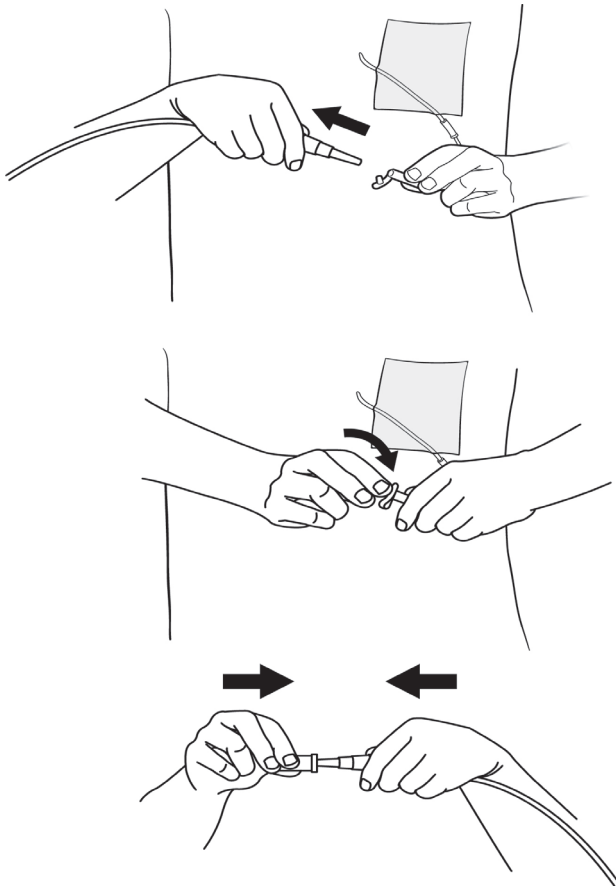

- B. Pull out the tip of the feeding container tubing. Replace the cap on your feeding tube and the feeding container tubing.

## Step 7: Flush your feeding tube again. Repeat step 4 (page 14).



## **Do these things to stay safe:**

- ✓ Wash your hands with soap and water before you begin your feeding.
- ✓ Stay in a sitting position during your feeding. Don't lay down flat.
- ✓ Raise your upper body at least 30 to 45 degrees.
- ✓ Stay upright after your feeding. Don't lie flat for 1 hour after your feeding is finished. If you lie flat the feeding formula could back up from your stomach and into your throat.

## Section E: After using your feeding container tubing

### Read this section to learn:

- ✓ How to clean your feeding container after feeding
- ✓ When to use a new container and tubing

### Follow these steps to clean your feeding container and tubing:

#### Step 1: Rinse your feeding container and tubing.

After each feeding, the feeding container needs to be rinsed with water. This is so no formula is left in the container or tube.

- Take your feeding container down and bring it to a sink.
- Remove the tip cover from the tubing and open the roller clamp. Put the end of the tubing into the sink.
- Open the top of the feeding container and pour water into the container. Hold the container above your head to get the water to run through the tubing. Make sure you hold the end of the tubing into the sink.
- Repeat the rinsing until there is no formula left in the feeding container or tubing.

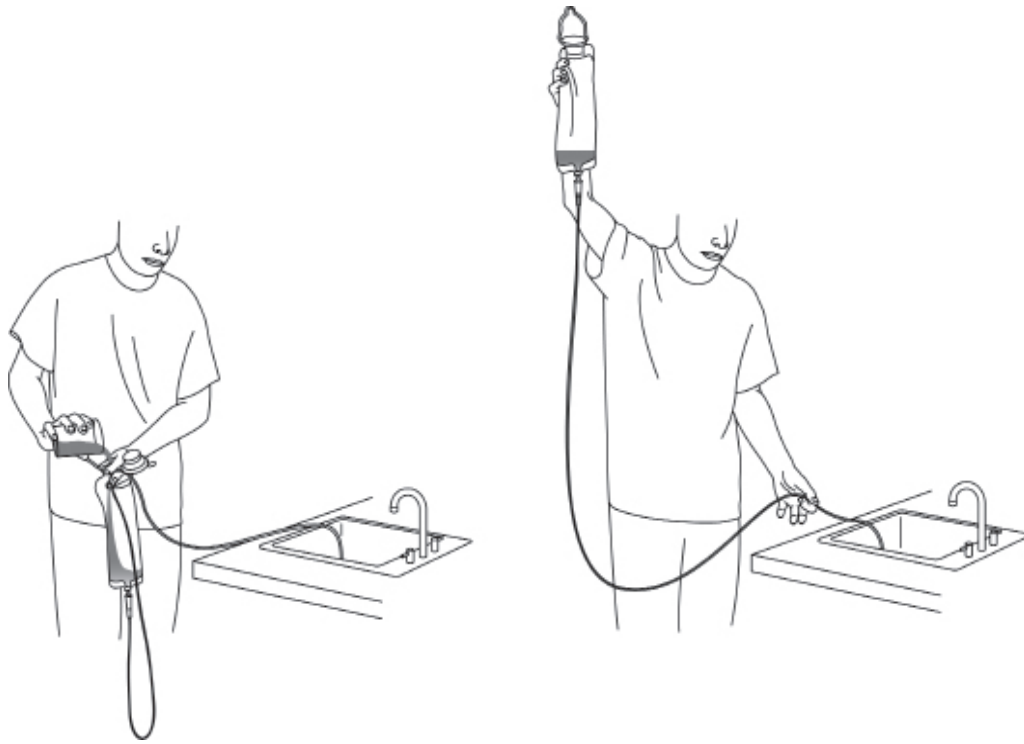

## Step 2: Clean your feeding container and tubing at the end of each day.

- A. Repeat **Step 1**, but add a small amount of liquid dish soap to the water.
- B. Rinse well to make sure all of the soap is removed.
- C. Hang the feeding container and tubing to dry.
- D. Your feeding container and tubing are ready for use the next day.

## When do I need a new container and tubing?

You will get a new feeding container each day while you are in the hospital. You can use a feeding container longer when at home. Throw away your feeding container if formula gets built up inside the container.

- If you have a **feeding container with tubing attached to it**, change the container once a week.
- If you have a **feeding container with separate tubing**, change the container once a month and the tubing once a week.

## Section F: Common problems and what to do

### Here are some common problems you may have with your feeding tube:

- nausea and/or vomiting
- diarrhea
- constipation
- blocked feeding tube

### Nausea and vomiting

Nausea and vomiting are unpleasant symptoms that can happen with illness. They can also be related to your tube feeding.

Give yourself your feeding at the rate suggested by your dietitian to help prevent nausea and vomiting.

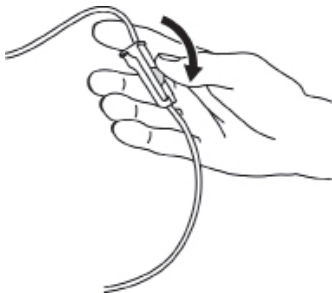

If you are doing this and still have nausea, the rate may be too fast for you. Slow the rate of your feeding by rolling the roller clamp down (↓) a little bit on the tubing. If you continue to have nausea after slowing the rate you should call your LHIN Home and Community Care dietitian or nurse.

### Diarrhea

Diarrhea can be caused by many things. Run your formula at the rate suggested by your dietitian. If you are doing this and still have loose bowel movements after your feeding, the rate may be too fast for you. Slow the rate of your feeds by rolling the clamp down (↓) a little bit on the tubing.

You can easily get dehydrated when you have diarrhea. Contact your dietitian or nurse providing your care at home from LHIN Home and Community Care if you have diarrhea.

## Constipation

Constipation can be caused by many things. Constipation is most commonly caused by:

- pain medicine
- not taking enough fluid through your feeding tube

If you are constipated, try giving yourself more water through your feeding tube during the day. Contact your dietitian or nurse providing your care at home from LHIN Home and Community Care if your constipation does not get better.

## Blocked feeding tube

### **How do I keep my feeding tube from becoming blocked?**

Flush your feeding tube with at least 60 millilitres of room temperature water before and after you finish a feeding. Also flush with 60 millilitres of water after any crushed medicine you give yourself. Make sure to crush your medicine well.

### **What should I do if my feeding tube becomes blocked?**

If your feeding tube becomes blocked or if the flow is slower than normal:

- Try to flush your tube with warm water. Use **gentle pressure**.
- Contact your nurse providing your care at home from the LHIN Home and Community Care, or your doctor if flushing does not unblock your tube.

### **What should I do if my feeding tube falls out?**

If your tube falls out:

- **Don't** try to flush or replace the feeding tube yourself.
- Cover the area where the tube was in your body with a clean paper towel or piece of gauze.
- Call your doctor or go to the nearest hospital emergency department.



## Call your health care team right away if:

- You have nausea and vomiting for 2 days
- You have 3 or more loose bowel movements per day
- You have not had a bowel movement for 4 days
- Flushing does not unblock your tube
- Your feeding tube falls out

### Notes:

---

---

---

---



### Have feedback about this document?

Please fill out our survey. Use this link: [surveymonkey.com/r/uhn-pe](https://surveymonkey.com/r/uhn-pe)

Visit [www.uhnpatienteducation.ca](http://www.uhnpatienteducation.ca) for more health information. Contact [pfep@uhn.ca](mailto:pfep@uhn.ca) to request this brochure in a different format, such as large print or electronic formats.

© 2022 University Health Network. All rights reserved. Use this material for your information only. It does not replace advice from your doctor or other health care professional. Do not use this information for diagnosis or treatment. Ask your health care provider for advice about a specific medical condition. You may print 1 copy of this brochure for non-commercial and personal use only.